



Assembly and Operating Manual



SPECIFICATION

- Length 25.19 inch (640mm)
- Wing Span 27.76 inch (705mm)
- Flying Weight 11.64 oz (330g)



Assembly and Operating manual

VIPER

Dear customer,

Congratulations on your choice of a factory assembled model aircraft from Max-Thrust and thank you for placing your trust in us.

Very little preparation work is required to get this model ready to fly. To operate your new model safely it is important that you read through all of the instructions and safety information included with your model, before you fly it for the first time.

The illustrations in this manual show the model with factory applied decals.

The Power System

The model is powered by a brushless outrunner motor and ducted fan, both of which are pre-installed.

The Radio Control System

To fly the Viper you will need a radio control system with at least four channels. 2.4GHz radios systems are recommended.

The servos for the ailerons and the elevators are factory-installed.

The power for the receiver is drawn from the electronic speed controller's integral BEC system.

The electronic speed controller is located inside of the fuselage, in front of the ducted fan.

To check the model's operating systems, first set the control surface servos to neutral by setting the trims to center and leaving throttle stick and trim to the lowest position.

When you wish to fly the model, always make sure the transmitter is "ON". Move the throttle stick to the "OFF" position as well. Then connect the battery to the electronic speed controller.

Proceed to power down in reverse order: disconnect the battery from the electronic speed controller first, and then switch off the transmitter.

Glue Joints With Suitable Adhesives

Foam safe epoxy is recommended and available from most reputable model retail shops.

Trial-fit all parts "dry" before applying glue.

Follow the recommended curing time suggested by the glue manufacturer. Allow the glue to fully cure (harden) to the point where the joint can be placed under stress.

Kit Contents

Fuselage, with motor, electronic speed controller and servos

Clear canopy and cockpit

Left / right wing panels with ailerons

Left / right tail plane panels with elevators and vertical stabilizer

Accessories

1 x 20A Brushless ESC (Electronic Speed Controller)

Fig. 1 Open the box and check all the parts.

Parts Illustration



Parts List

NO.	Description
1	Fuselage
2	Nose Cone
3	Cockpit Canopy
4	Wing Set - One Wing Panel
5	Tail Set - One Horizontal Stabilizer
6	Tail Set - One Vertical Stabilizer
7	Push Rod Set x 4 (2 x long, 2 x short)
8	Servo fairing
9	Control horn and support plate x 4
10	Ventral fins

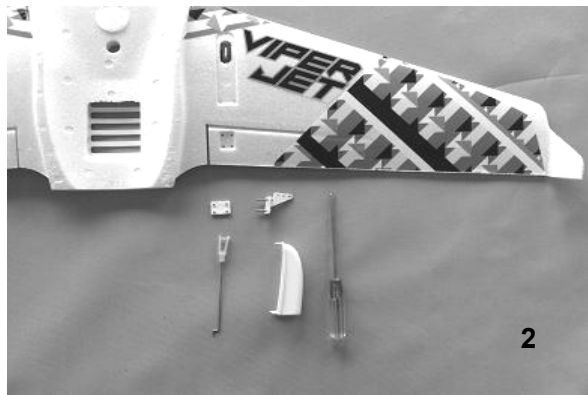

Fig. 2 - Locate the short push rod set.

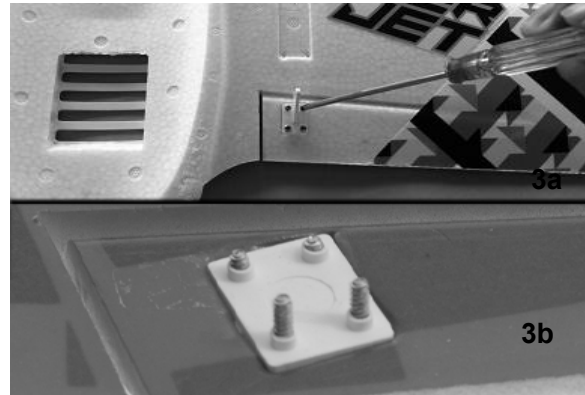

Fig. 3a - Install the aileron control horn, ensuring the screws are screwed through the control surface into the support plate - **Fig. 3b**

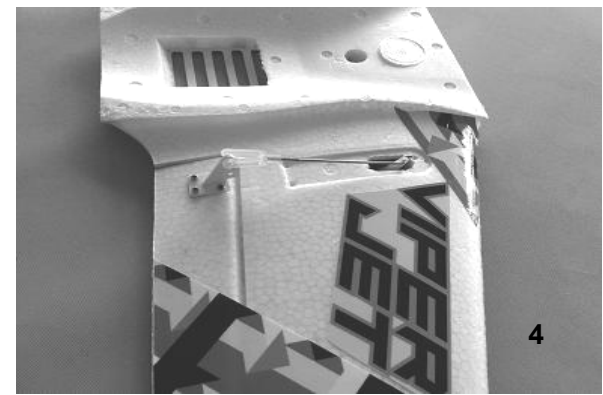

Fig. 4 - Connect the push rod to the aileron servo arm and control horn.



Fig. 5 - Glue the servo fairing.

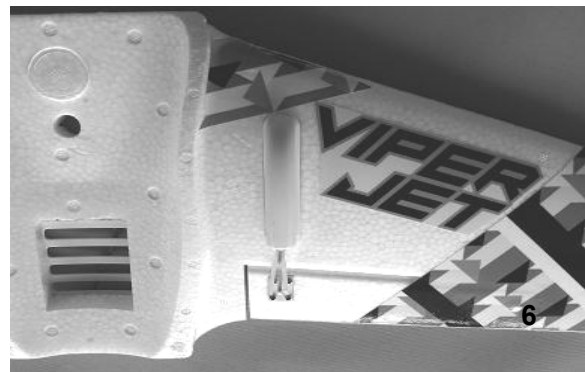

Fig. 6 - Install the Servo fairing.

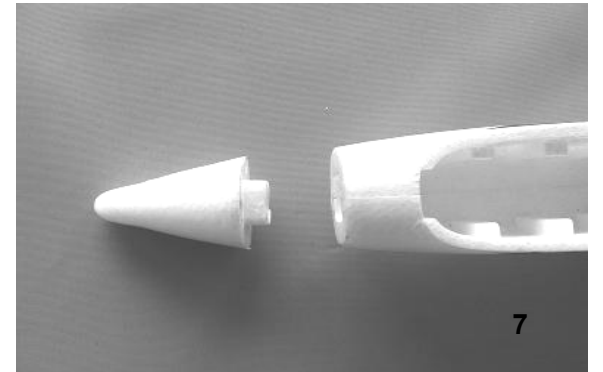

Fig. 7 - Locate the fuselage and nose cone.

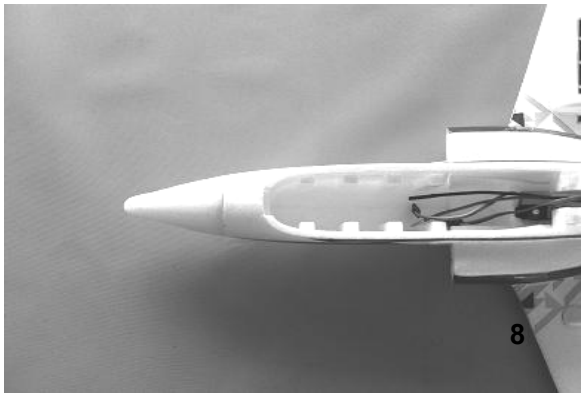

Fig.8 - The nose cone is held in place by magnets and can be lifted off.

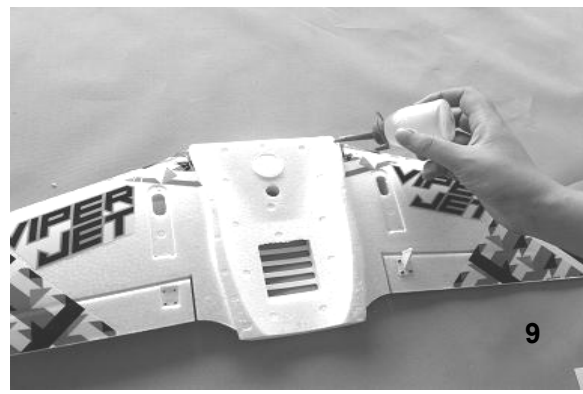

Fig. 9 - Apply glue to the mounting area of the main wing.

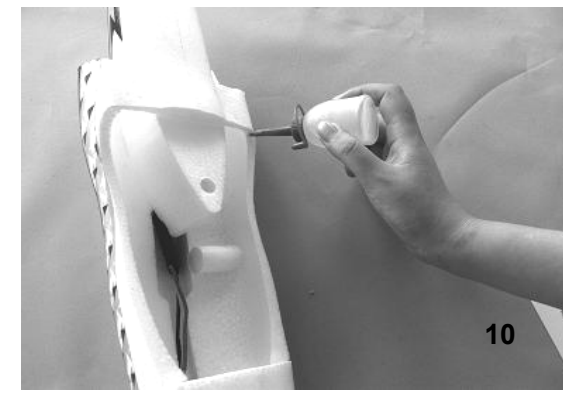

Fig. 10 - Apply glue to the saddle.



Fig. 11 - Thread the aileron servo lead up through the fuselage and into the receiver bay before gluing the wings in place.

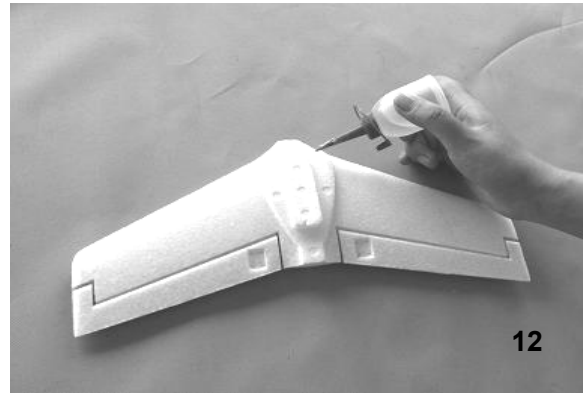

Fig. 12 - Apply glue to the underside of the horizontal stabilizer.

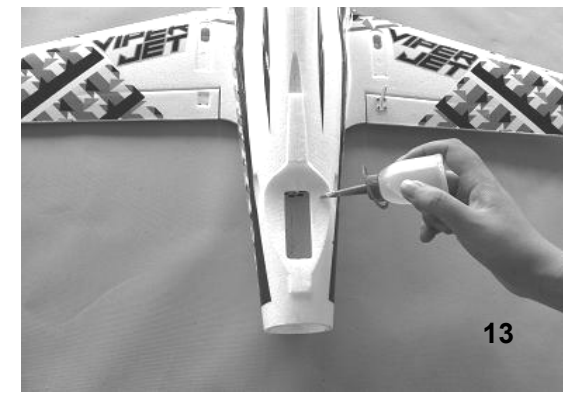

Fig.13 - Apply glue to the tail end of the fuselage of where the horizontal stabilizer sits.

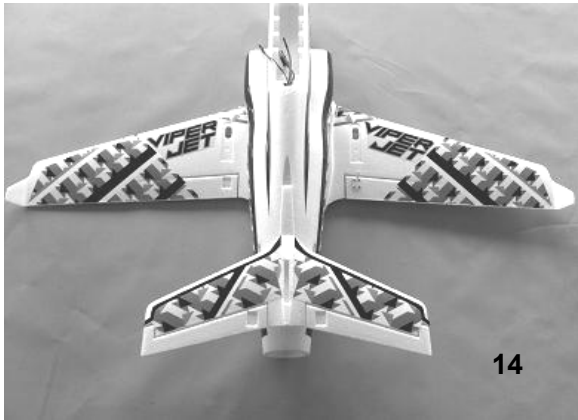

Fig. 14 - The photo shows the finished view after gluing the horizontal stabilizers in place.



Fig. 15 - Apply glue to the base of the Vertical Stabilizer.

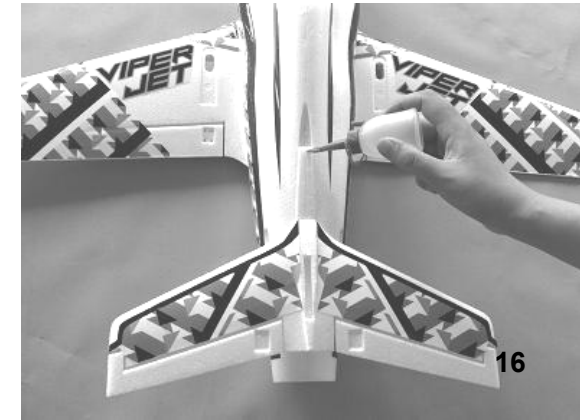

Fig. 16 - Apply glue to the slot of where the vertical stabilizer sits.

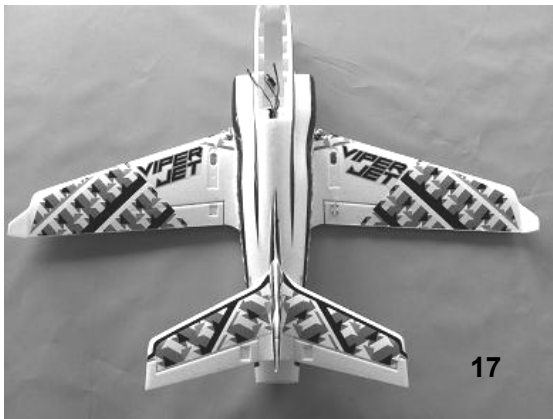

Fig. 17 - The photo shows the finished view after gluing the vertical stabilizers in place.

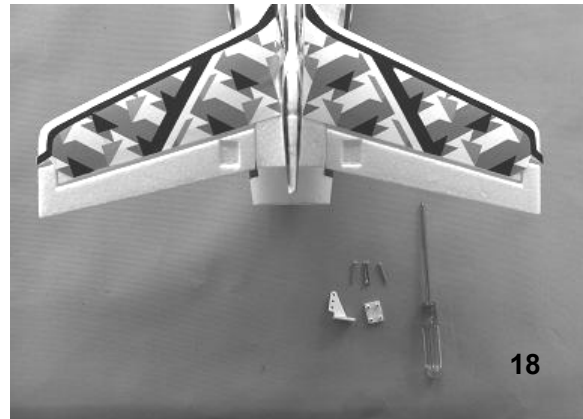

Fig. 18 - Install the elevator control horn, ensuring the screws are screwed through the control surface into the support plate.

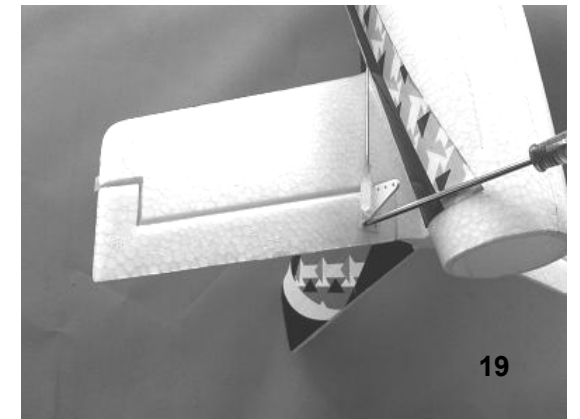

Fig. 19 - Connect the push rods to the elevator servo arm and then to the elevator control horn

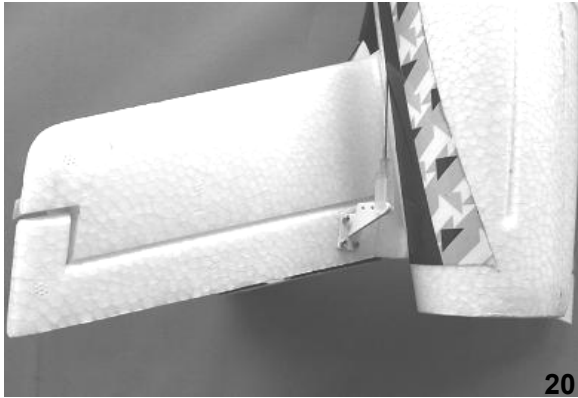

Fig. 20 - The photo shows the finished view.

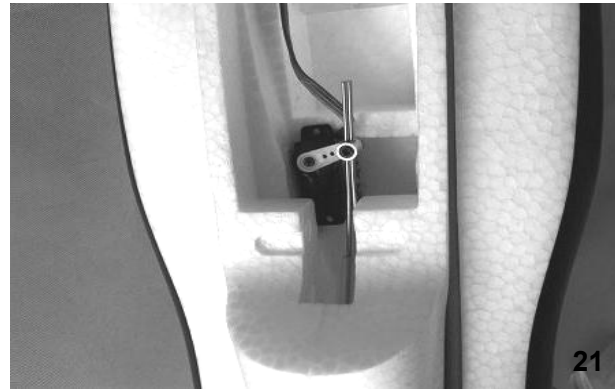

Fig. 21 - Connect the elevator push rods to the arm of servo.

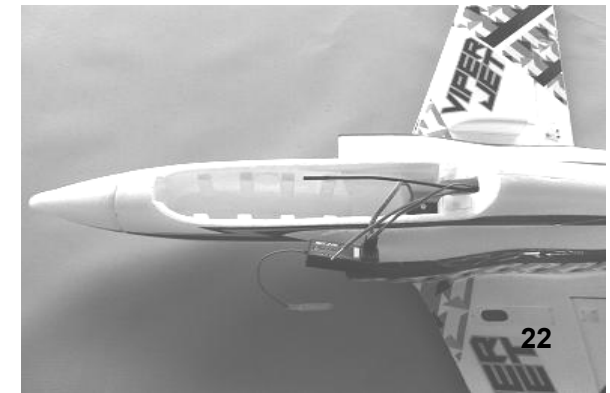

Fig. 22 - Connect the electronic speed controller and servos to the receiver. Refer to your radio instructions for the correct channel assignments and polarities. .

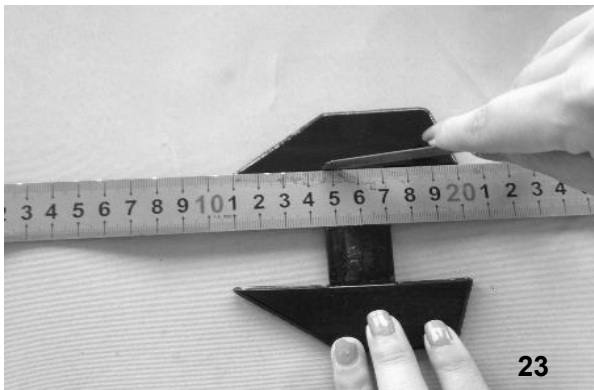

Fig. 23 - Locate the Ventral Fins. Cut apart for assembly as shown.

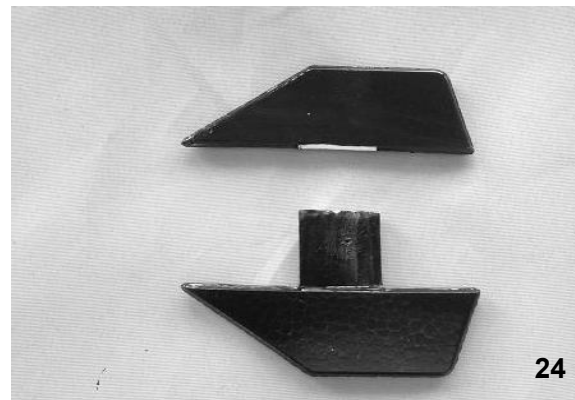

Fig. 24 - Ventral fins shown after being separated

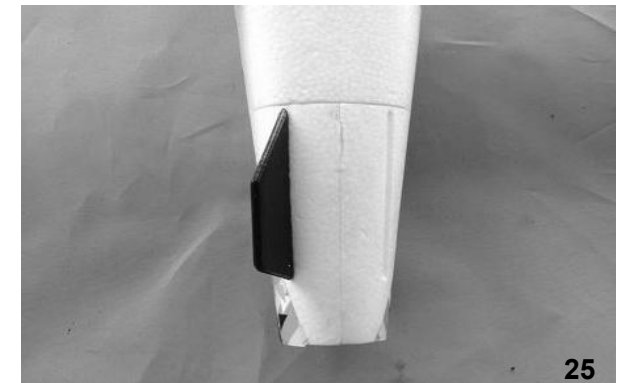

Fig. 25 - Glue them into the slots (glue not included).

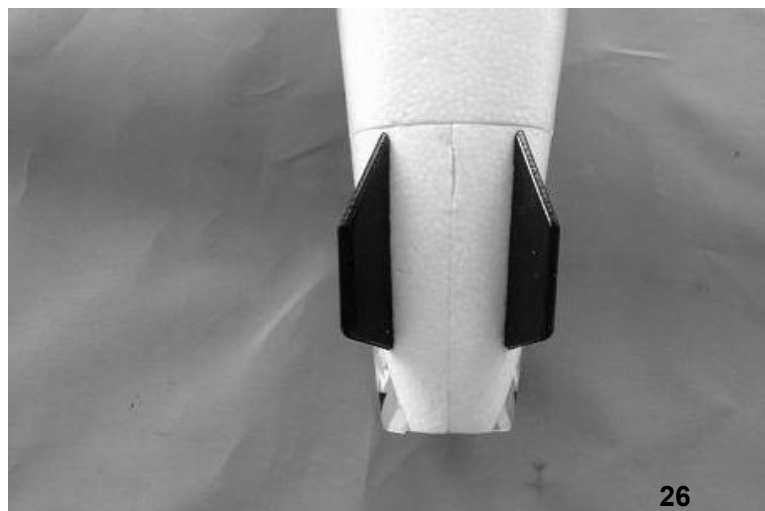

Fig. 26 - Photo shows Ventral fins in attached position

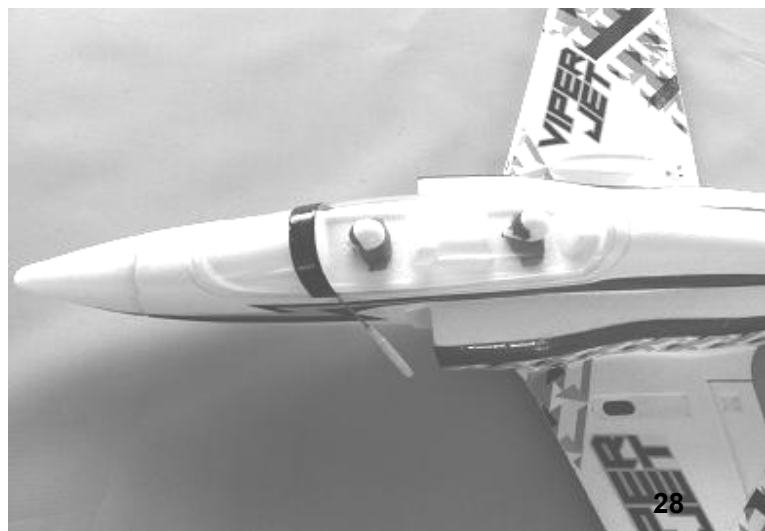

Fig. 28 - Place the fully charged flight battery in the fuselage and connect it to the electronic speed controller (Be sure the transmitter is "ON" first). The canopy is held in place by magnets and can be lifted off.

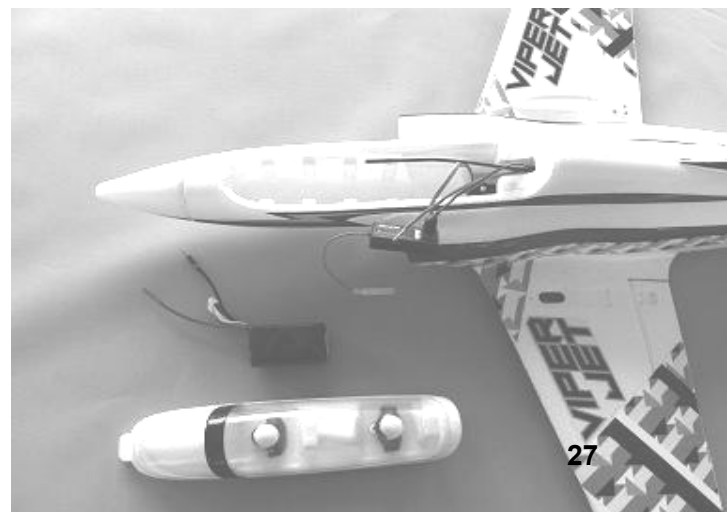

Fig. 27 - Locate the battery and canopy. Charge the battery according to the safety instructions before installing.

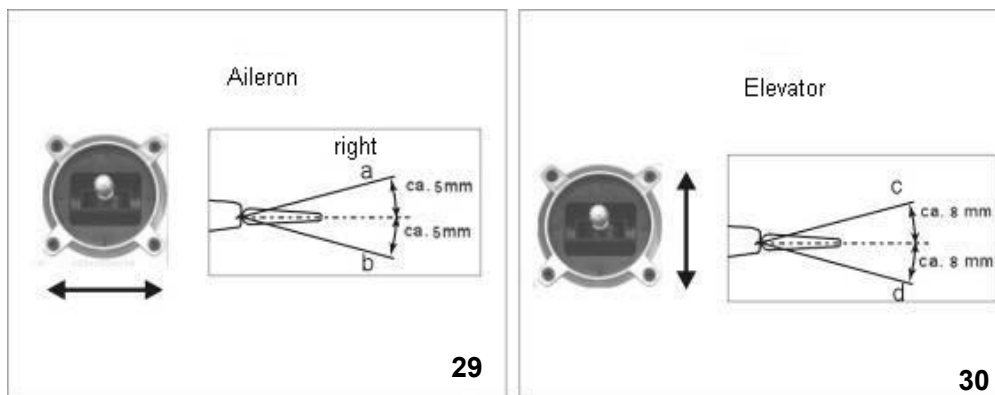

Fig. 29 and 30 - Checking Ailerons and Elevators

- Check that the control surfaces respond to the appropriate movements of the transmitter joysticks. If not, swap over the servo leads at the receiver.
- Check the neutral position of the control surfaces; you may need to screw the clevises in or out to correct any discrepancy.
- Stand behind the model.
- Check the direction of rotation of the servos:
- Move the aileron stick to the right (a), and the right aileron (a) must rise up, the left aileron (b) fall down.
- Pull the elevator stick back towards you (c), and the trailing edge of both elevators should rise (c).
- If either function works in the wrong way, correct it using your transmitter's servo reverse switch for that channel.

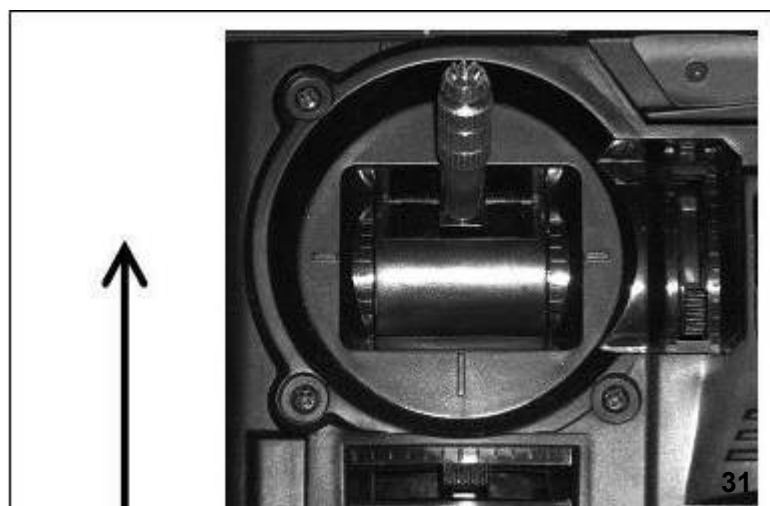

Fig. 31 - Checking the power system

- Hold the model securely.
- Remove any loose objects such as cloths, tools, etc from the area in front of the model, as they could easily be sucked into the ducted fan.
- Open the throttle (stick forward): the motor should now run and you should feel a strong air flow rushing out from the tail end of the model.
- Move the throttle stick back to the "OFF" position.
- Disconnect the battery from the electronic speed controller and then switch the transmitter off

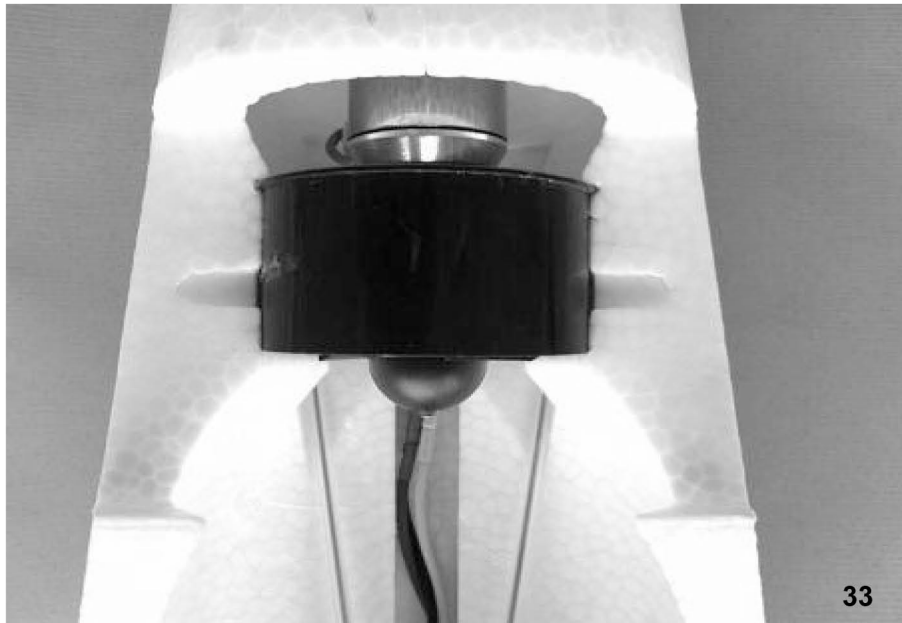
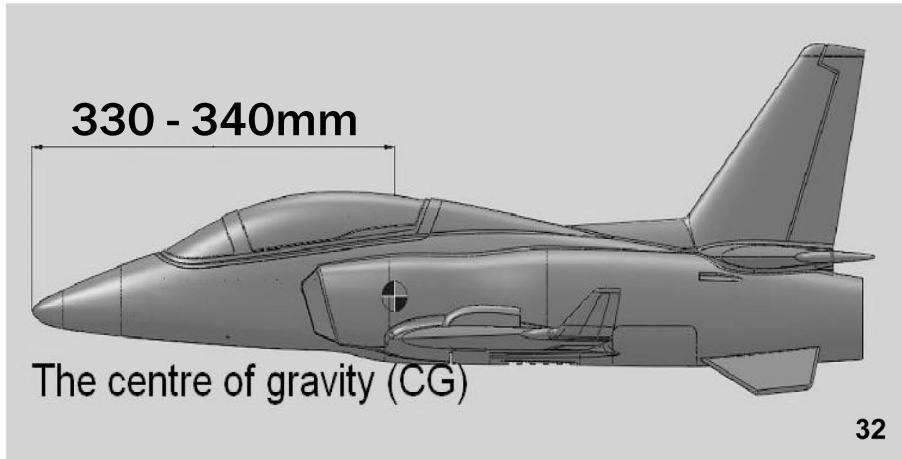

Fig. 32 - Checking the model's Balance

- Place the battery in its compartment without connecting.
- Mark the Centre of Gravity (CG) on both sides of the fuselage; the position is shown in the photo.
- Support the model at the marked points and allow it to hang freely. When correctly balanced the airplane will remain horizontal with the nose slightly down.
- If necessary, adjust the position of the flight battery to achieve the correct CG.
- Mark the battery location in the fuselage, so that you can be sure of positioning it correctly after recharging.
- Pack scrap pieces of foam around the battery in its final position, otherwise there is a danger of it shifting in flight and altering the model's balance.
- Charge the flight battery and the model is ready for flight.

Fig. 33 - Access to the ducted fan unit and electronic speed controller

- The ducted fan unit is accessible from underneath, if you need to carry out maintenance work or repairs.
- Ensure that the wire colors match correctly.

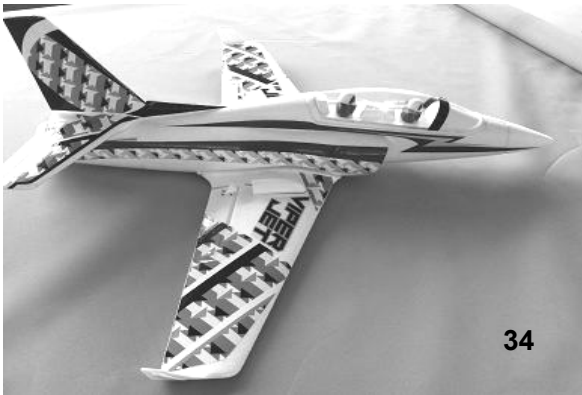

Fig. 34 - Congratulations, you have completed the assembly process. We hope you enjoy flying your new model



Test Flying - Notes on flying the airplane

- For the first flight you should wait for a relatively calm day with no more than a gentle breeze.
- A good flying site is a large, flat, open field; well away from trees, fences, high-tension overhead cables and other potentially dangerous obstacles.
- Carry out a complete check of the working systems.
- We recommend that you ask an experienced modeler to help you initially; to give the model a fairly powerful hand-launch.
- The model must be launched directly into any existing wind.
- Switch the motor on, and launch the airplane strongly into the wind, with the fuselage and wings leveled.
- Allow the Viper to fly straight and level initially; don't try to turn it when it is close to the ground.
Adjust the trims if necessary so that the model settles into a steady climb.
- Check the model's response to control commands from the transmitter.
- You may need to increase or reduce the control surface travels once the model is back on the ground.
- Take the airplane up to a safe height and check its stalling speed.
- Keep the speed well up on the landing approach to avoid stalling.
- If you had to move the trims during the flight, correct the mechanical linkages before flying again. This allows you to re-centre the trims, so that full trim travel is available for subsequent flights.
- We reserve the right to introduce technical modifications and suggest that you check our website for updates.

CENTURYUK

